

1

(IT) INSERIRE
(GB) INSERT
(E) CUBRIR
(D) EINSCHIEBEN
(F) ENFILER
(P) INSERIR
(NL) BEVESTIG

3

(IT) INSERIRE
(GB) INSERT
(E) CUBRIR
(D) EINSCHIEBEN
(F) ENFILER
(P) INSERIR
(NL) BEVESTIG

(x4)

2

(IT) VEDERE LA TABELLA APPLICABILITA' ALLEGATA PER LA SCELTA DEL TIRANTE
(GB) SEE THE ATTACHED APPLICATION TABLE FOR THE COUPLER CHOICE
(E) CONSULTE LA TABLA DE APLICABILIDAD ADJUNTA PARA SELECCIONAR LOS TIRANTE APROPRIADO
(D) SIEHE DIE BEILIEGENDE ANWENDUNGSTABELLE UM DEN RICHTIGEN KUPPLER ZU WÄHLEN
(F) VOIR LE TABLEAU D'APPLICATION ATTACHE' AU FIN DE CHOISIR LE TIRANT LE PLUS CORRECT
(NL) KIJK IN DE BIJGEOVOEGDE APPLICATIETABEL VOOR DE JUISTE KEUZE MONTAGEBEUGELS

(IT) SVITARE
(GB) UNSCREW
(E) AFLOJAR
(D) ABSCHRAUBEN
(F) DEVISSER
(P) DESAPARAFUSAR
(NL) OPENSCHROEVEN

A

(IT) MONTAGGIO TIRANTE 2
(GB) HOW TO ASSEMBLE COUPLER 2
(E) COMO MONTAR LOS TIRANTE 2
(D) ZUSAMMENBAU DER KOPPLER 2
(F) MONTAGE TIRANT 2
(NL) MONTAGE VAN DE TREKSTANG 2

(IT) SOSTITUIRE
(GB) TO REPLACE
(E) APRETAR
(D) ERSETZEN
(F) REMPLACER
(NL) VERVANGEN

B

(IT) AVVITARE
(GB) TO SCREW
(E) APRETAR
(D) FESTSCHRAUBEN
(F) VISSER
(P) APERTAR
(NL) VASTSCHROEVEN

C

(x4)

4

(IT) INSERIRE
(GB) INSERT
(E) CUBRIR
(D) EINSCHIEBEN
(F) ENFILER
(P) INSERIR
(NL) BEVESTIG

A

B

(x4)

5

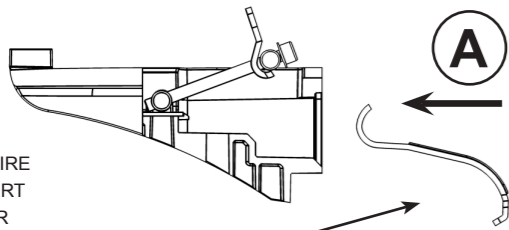

(IT) INSERIRE
(GB) INSERT
(E) CUBRIR
(D) EINSCHIEBEN
(F) ENFILER
(P) INSERIR
(NL) BEVESTIG

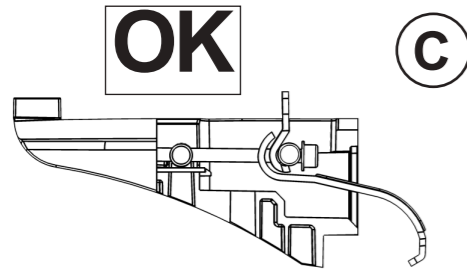
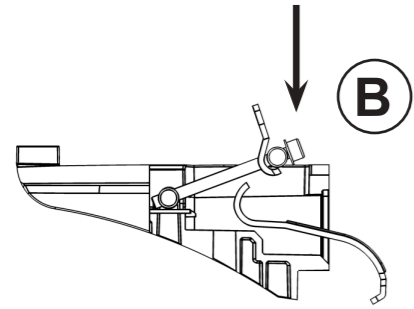

(x4)

6

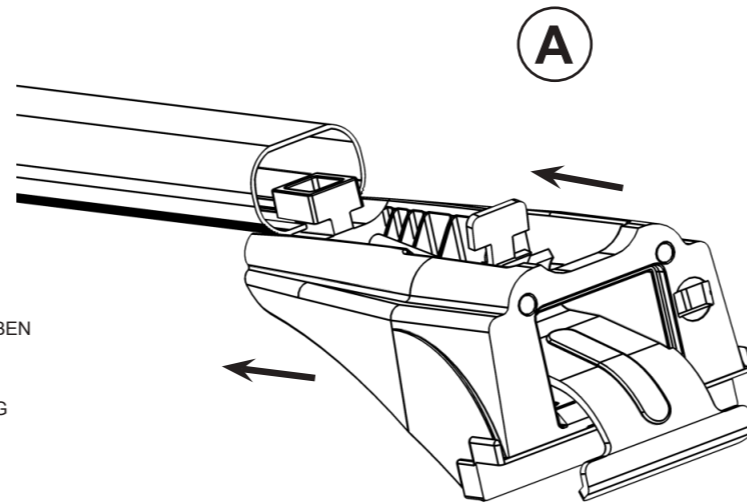

(IT) INSERIRE
(GB) INSERT
(E) CUBRIR
(D) EINSCHIEBEN
(F) ENFILER
(P) INSERIR
(NL) BEVESTIG

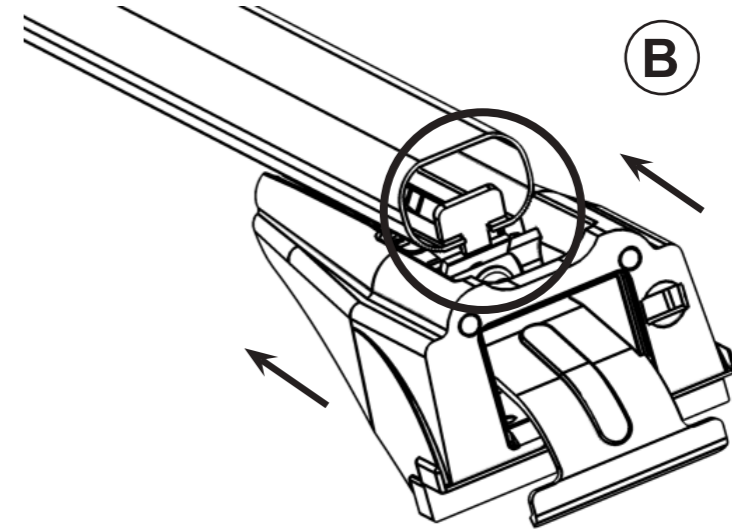

(x4)

7

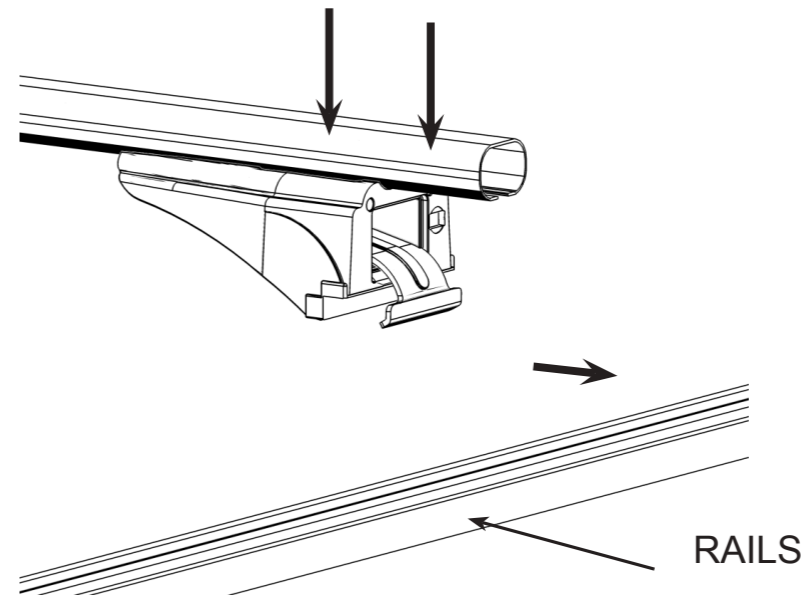

8

(IT) CENTRARE IL P. TUTTO SUL TETTO
(GB) CENTRE THE UNIVERSAL BAR CARRIER ON THE ROOF
(E) CENTRAR EL PORTAEQUIPAJES SOBRE EL TECHO
(D) LASTENTRÄGER AUF DEM DACH ZENTRIEREN
(F) CENTRER LE PORTE-TOUT SUR LE TOIT
(P) CENTRAR AS BARRAS PORTA BAGAGENS NO TEJADILHO
(NL) PLAATS DE UNIVERSELE DRAGER IN HET MIDDEN VAN HET DAK



9

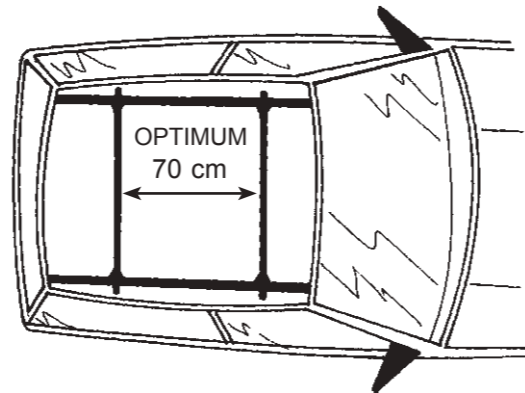

10



(IT) AVVITARE
(GB) TO SCREW
(E) APRETAR
(D) FESTSCHRAUBEN
(F) VISSER
(P) APERTAR
(NL) VASTSCHROEVEN

(x4)

11

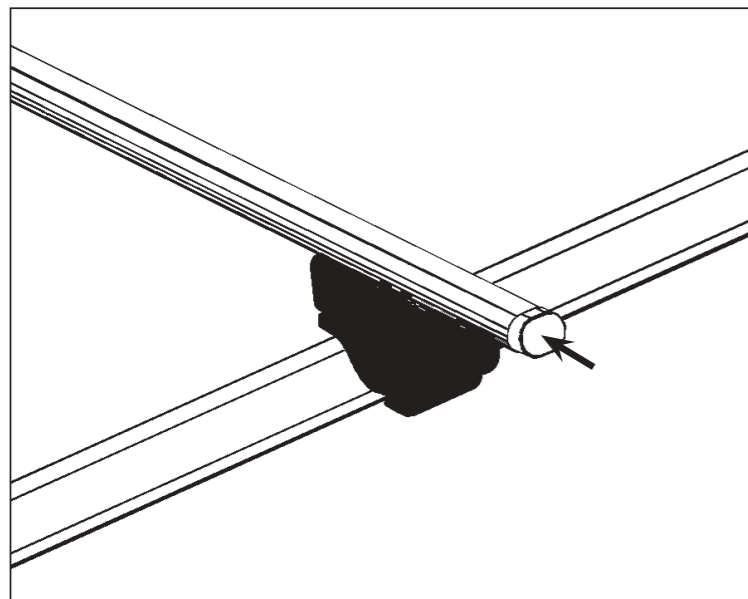

(IT) INSERIRE
 (GB) INSERT
 (E) CUBRIR
 (D) EINSCHIEBEN
 (F) ENFILER
 (P) INSERIR
 (NL) BEVESTIG

(x4)

12

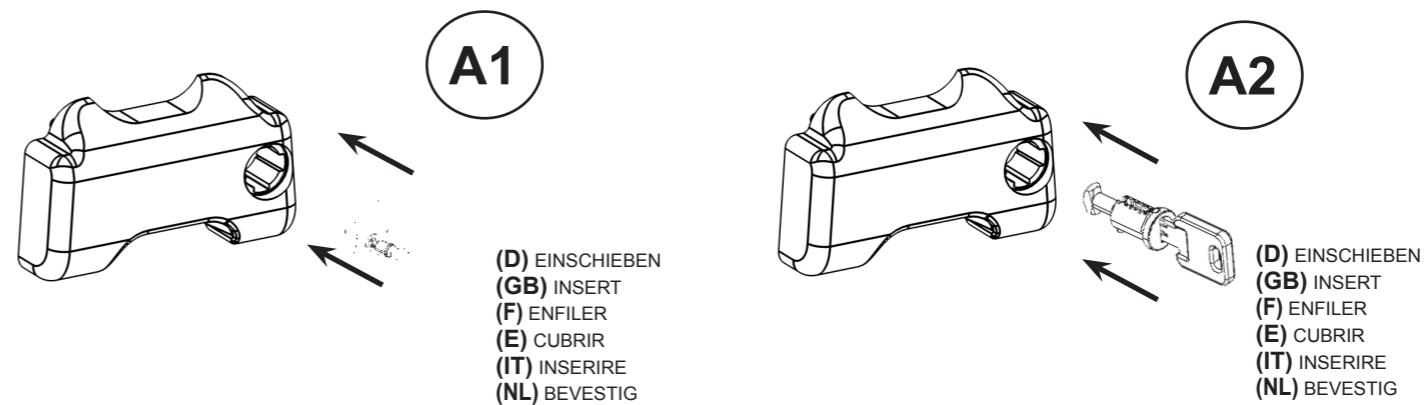

(D) EINSCHIEBEN
 (GB) INSERT
 (F) ENFILER
 (E) CUBRIR
 (IT) INSERIRE
 (NL) BEVESTIG

(D) EINSCHIEBEN
 (GB) INSERT
 (F) ENFILER
 (E) CUBRIR
 (IT) INSERIRE
 (NL) BEVESTIG

X2

X2

B

C

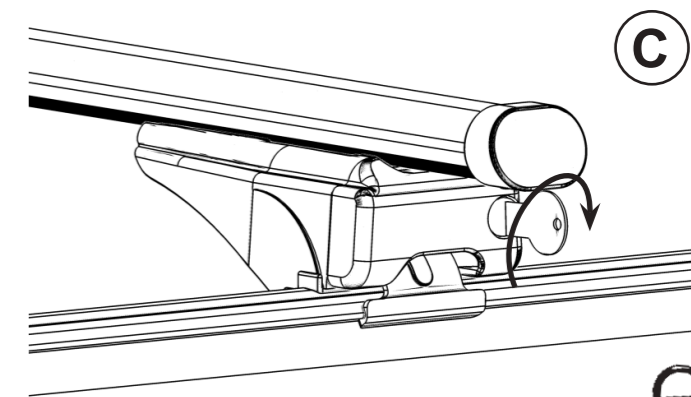
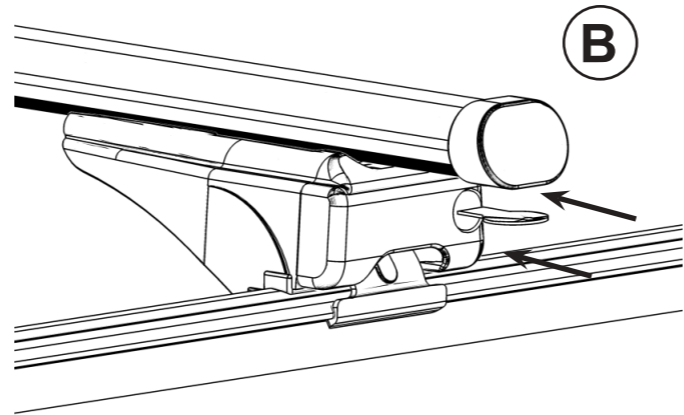

(x4)

TOT. = Kg 100 MAX

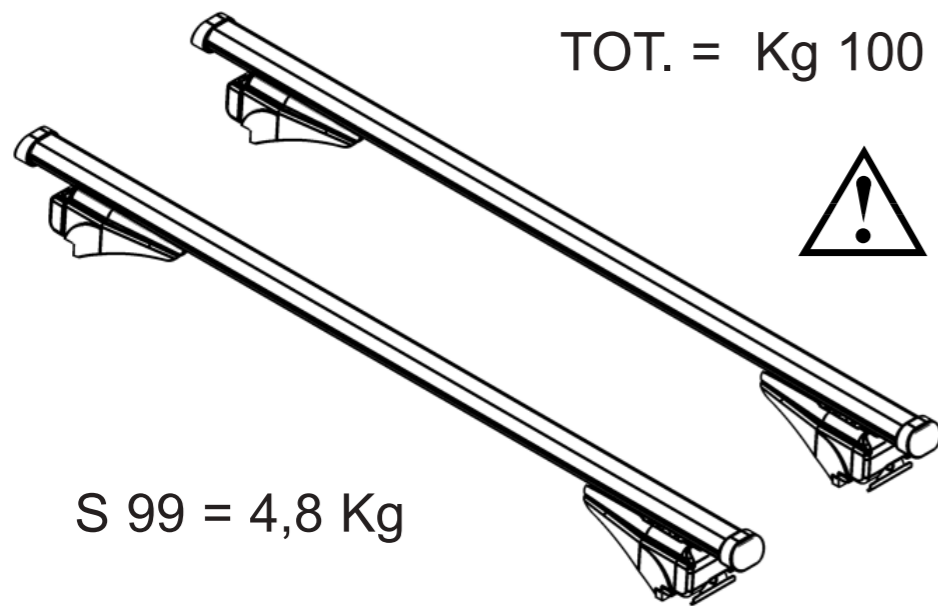

S 99 = 4,8 Kg

(IT) MODELLI AUTO (GB) CARS (E) COCHES (D) WAGEN (F) VOITURES (P) MODELO AUTO (NL) AUTO	(IT) TIRANTE (GB) COUPLER (E) TIRANTE (D) KOPPLER (F) TIRANT (NL) TREKSTANG
ALFA ROMEO 159 SW (06->11) Rail aperti/Railings/Mit Reling	2
AUDI A3 Sportback 5P (04->08) Rail chiusi/Integrated rails/Geschlossener Reling	1
AUDI A3 Sportback 5P (08->12) Rail chiusi/Integrated rails/Geschlossener Reling	1
AUDI A3 Sportback 5P (12->) Rail chiusi/Integrated rails/Geschlossener Reling	1
AUDI A4 Avant SW (08->15) Rail chiusi/Integrated rails/Geschlossener Reling	1
AUDI A4 Avant SW (15->) Rail chiusi/Integrated rails/Geschlossener Reling	1
AUDI A4 Allroad SW (09->16) Rail aperti/Railings/Mit Reling	1
AUDI A6 Avant SW (05->11) Rail chiusi/Integrated rails/Geschlossener Reling	1
AUDI A6 Avant SW (11->) Rail chiusi/Integrated rails/Geschlossener Reling	1
AUDI A6 Allroad SW (12->) Rail aperti/Railings/Mit Reling	1
AUDI Q3 SUV (11->) Rail chiusi/Integrated rails/Geschlossener Reling	1
AUDI Q7 SUV (06->09) Rail chiusi/Integrated rails/Geschlossener Reling	1
AUDI Q7 SUV (09->15) Rail chiusi/Integrated rails/Geschlossener Reling	1
BMW Serie 2 Active Tourer MPV (14->) Rail chiusi/Integrated rails/Geschlossener Reling	1
BMW Serie 2 Gran Tourer MPV (15->) Rail chiusi/Integrated rails/Geschlossener Reling	1
BMW Serie 3 Touring SW (10->12) Rail chiusi/Integrated rails/Geschlossener Reling	1
BMW Serie 3 Touring SW (12->) Rail chiusi/Integrated rails/Geschlossener Reling	1
BMW Serie 5 Touring SW (10->) Rail chiusi/Integrated rails/Geschlossener Reling	1
BMW X1 SUV (09->15) Rail chiusi/Integrated rails/Geschlossener Reling	1
BMW X1 SUV (15->) Rail chiusi/Integrated rails/Geschlossener Reling	1
BMW X3 SUV (10->) Rail chiusi/Integrated rails/Geschlossener Reling	1
BMW X5 SUV (07->13) Rail chiusi/Integrated rails/Geschlossener Reling	1
CADILLAC SRX SUV (10->) Rail aperti/Railings/Mit Reling	2
CHEVROLET / DAEWOO Captiva SUV (06->15)	2
CITROËN C3 Picasso MPV (09->) Rail aperti/Railings/Mit Reling	1
CITROËN C4 Aircross SUV (12->) Rail chiusi/Integrated rails/Geschlossener Reling	2
DR DR 5 SUV (07->) Rail aperti/Railings/Mit Reling	2
FIAT Panda III 5P (12->) Rail chiusi/Integrated rails/Geschlossener Reling	2
FIAT Panda III Cross 5P (14->) Rail aperti/Railings/Mit Reling	2
FORD Edge SUV (16->) Rail chiusi/Integrated rails/Geschlossener Reling	2
FORD Focus III SW (11->) Rail chiusi (no rail in plastica)/Integrated rails (no plastic rails)/Geschlossener Reling (keine Kunststoff Reling)	1
HONDA Civic IX Tourer SW (13->) Rail chiusi/Integrated rails/Geschlossener Reling	1
HYUNDAI ix35 SUV (10->15) Rail chiusi/Integrated rails/Geschlossener Reling	2
HYUNDAI Tucson III SUV (15->)	2
KIA Carens MPV (13->) Rail chiusi/Integrated rails/Geschlossener Reling	2
KIA Cee'd Sporty Wagon SW (12->) Rail chiusi/Integrated rails/Geschlossener Reling	2
KIA Sportage III SUV (10->15) Rail chiusi/Integrated rails/Geschlossener Reling	2
KIA Sportage IV SUV (16->) Rail chiusi/Integrated rails/Geschlossener Reling	2
MERCEDES Classe C SW (07->14) Rail aperti/Railings/Mit Reling	1
MERCEDES Classe E SW (09->16) Rail aperti/Railings/Mit Reling	1
MERCEDES GLA SUV (13->) Rail chiusi/Integrated rails/Geschlossener Reling	1
MERCEDES GLC SUV (15->) Rail chiusi/Integrated rails/Geschlossener Reling	1
MINI Countryman 5P (10->) Rail chiusi/Integrated rails/Geschlossener Reling	1
MITSUBISHI ASX SUV (10->) Rail chiusi/Integrated rails/Geschlossener Reling	2
MITSUBISHI Outlander III SUV (12->) Rail chiusi/Integrated rails/Geschlossener Reling	2
NISSAN Qashqai II SUV (13->) Rail aperti/Railings/Mit Reling	2
NISSAN X-Trail III SUV (14->) Rail aperti/Railings/Mit Reling	1
OPEL Astra H SW (04->10) Rail chiusi/Integrated rails/Geschlossener Reling	1
OPEL Astra J Sport Tourer SW (11->15) Rail chiusi/Integrated rails/Geschlossener Reling	1
OPEL Insignia Sports Tourer SW (09->) Rail chiusi/Integrated rails/Geschlossener Reling	1
OPEL Mokka SUV (12->) Rail chiusi/Integrated rails/Geschlossener Reling	1
OPEL Vectra C SW (03->05) Rail chiusi/Integrated rails/Geschlossener Reling	1
OPEL Vectra C SW (06->08) Rail chiusi/Integrated rails/Geschlossener Reling	1
OPEL Zafira B MPV (05->15) Rail chiusi/Integrated rails/Geschlossener Reling	1
OPEL Zafira C MPV (11->) Rail chiusi/Integrated rails/Geschlossener Reling	1
PEUGEOT 308 II SW (14->) Rail chiusi/Integrated rails/Geschlossener Reling	1
PEUGEOT 508 SW (11->) Rail chiusi/Integrated rails/Geschlossener Reling	2
RENAULT Kadjar SUV (15->) Rail chiusi/Integrated rails/Geschlossener Reling	1
RENAULT Megane III Sportour / Grandtour SW (09->16) Rail aperti/Railings/Mit Reling	2
RENAULT Talisman Sporter SW (16->) Rail chiusi/Integrated rails/Geschlossener Reling	2
SEAT Alhambra II MPV (10->) Rail aperti/Railings/Mit Reling	1
SEAT Altea Freetrack MPV (07->) Rail chiusi/Integrated rails/Geschlossener Reling	1
SEAT Altea XL MPV (06->) Rail chiusi/Integrated rails/Geschlossener Reling	1
SEAT Ibiza ST SW (10->) Rail chiusi/Integrated rails/Geschlossener Reling	1
SEAT Leon ST SW (13->) Rail chiusi/Integrated rails/Geschlossener Reling	1
SEAT Leon X-PERIENCE SW (15->) Rail chiusi/Integrated rails/Geschlossener Reling	1
SKODA Superb III Wagon SW (15->) Rail aperti/Railings/Mit Reling	1
SUZUKI SX4 S-Cross 5P (13->) Rail chiusi/Integrated rails/Geschlossener Reling	1
VOLKSWAGEN Cross Polo V 5P (10->)	1

(IT) MODELLI AUTO (GB) CARS (E) COCHES (D) WAGEN (F) VOITURES (P) MODELO AUTO (NL) AUTO	(IT) TIRANTE (GB) COUPLER (E) TIRANTE (D) KOPPLER (F) TIRANT (NL) TREKSTANG
VOLKSWAGEN Cross Up! 5P (14->) Rail aperti/Railings/Mit Reling	1
VOLKSWAGEN Golf Sportsvan MPV (14->) Rail aperti/Railings/Mit Reling	2
VOLKSWAGEN Passat VIII Variant SW (14->) Rail chiusi/Integrated rails/Geschlossener Reling	1
VOLKSWAGEN Tiguan I SUV (07->16) Rail aperti/Railings/Mit Reling	2
VOLKSWAGEN Tiguan II SUV (16->) Rail aperti/Railings/Mit Reling	1
VOLKSWAGEN Touran II MPV (15->) Rail aperti/Railings/Mit Reling	1
VOLVO V60 SW (10->) Rail chiusi/Integrated rails/Geschlossener Reling	1
VOLVO V60 Cross Country SW (16->) Rail chiusi/Integrated rails/Geschlossener Reling	1
VOLVO XC60 SUV (10->) Rail chiusi/Integrated rails/Geschlossener Reling	2
VOLVO XC90 II SUV (15->) Rail chiusi/Integrated rails/Geschlossener Reling	1

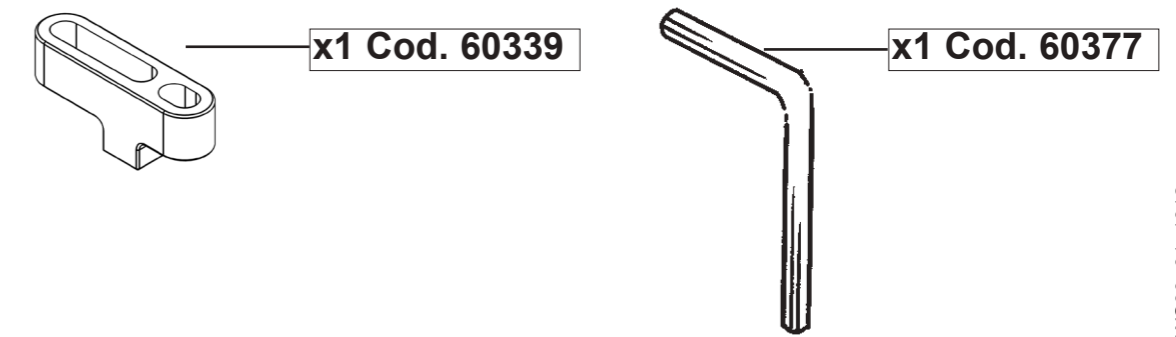
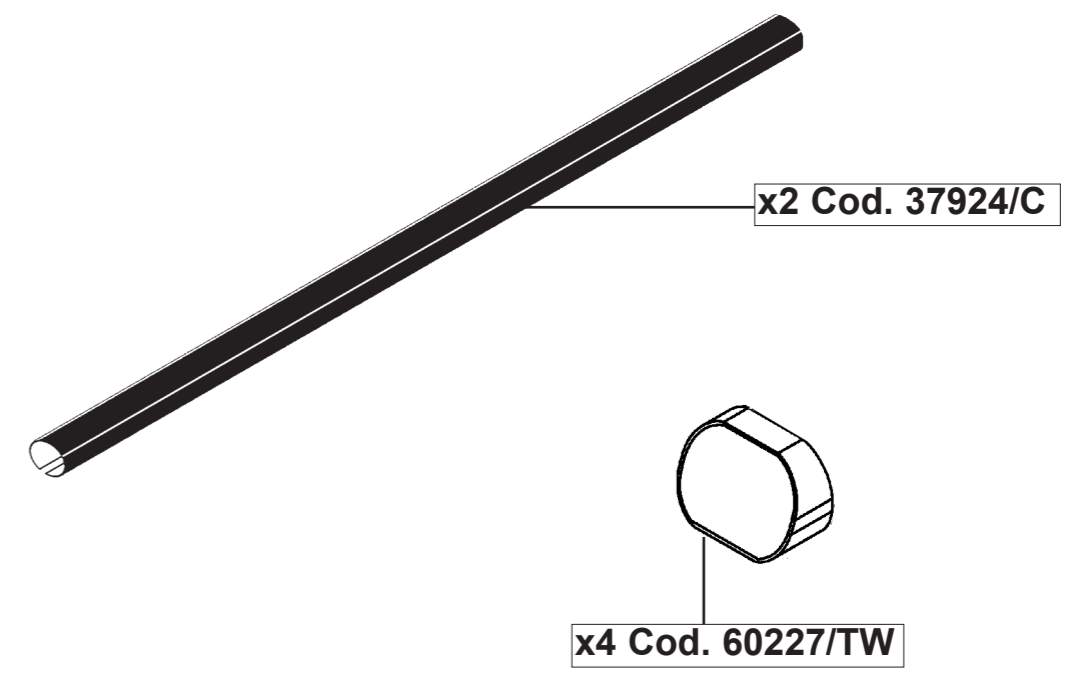
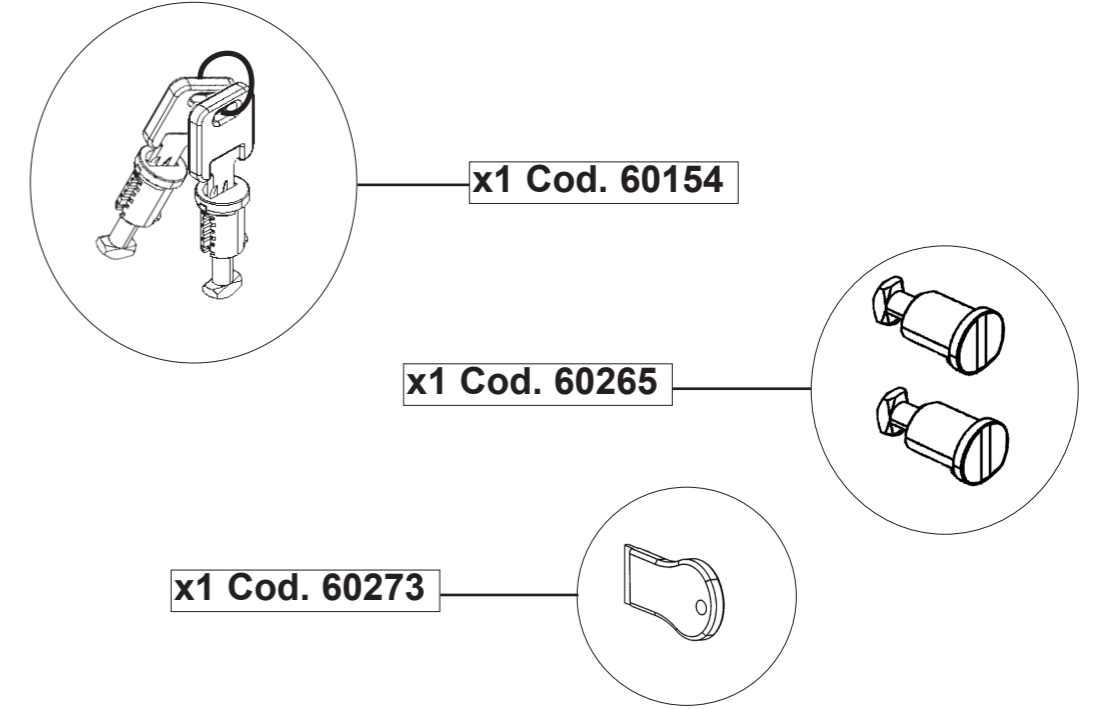
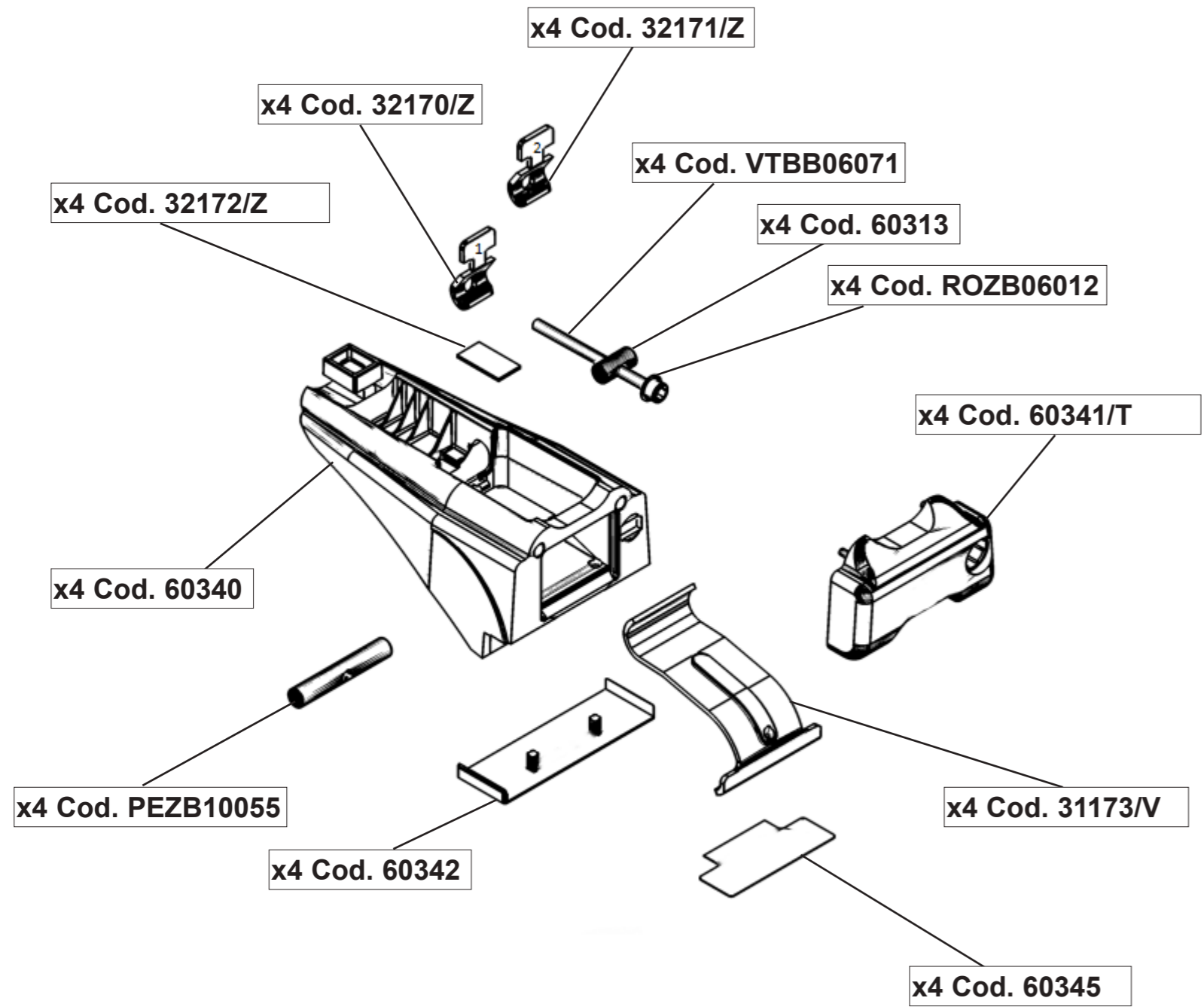

I NORME D'USO DESTINATE A PORTATUTTO UNIVERSALI CONFORMI ALLE NORME DIN 75302 E CONTRASSEGNA TI CON IL MARCHIO "GS".

- Effettuato il montaggio del portatutto, dopo alcuni chilometri ricontrrollare il fissaggio di tutte le viti.
 - È necessario periodicamente, anche in funzione del fondo stradale, controllare i fissaggi di tutte le viti.
 - Attenzione: la stabilità della vettura con portatutto montato può subire alterazioni nel comportamento su strada, nelle curve, nelle frenate ed in presenza di raffiche di vento. Si raccomanda quindi di guidare ed affrontare le curve a velocità moderata e di evitare brusche accelerate o frenate.
 - Per motivi di sicurezza e di risparmio carburante è preferibile smontare il portatutto in caso di inutilizzo.
 - **ATTENZIONE:** portata massima 50 kg distribuiti uniformemente sulle due barre.
- Attenzione: controllare sul libretto istruzioni della casa costruttrice la portata massima consentita dalla vostra vettura.

GB USING THE MULTI-PURPOSE RACK A3 PROVIDED FOR BY THE DIN 75302 STANDARD AND COUNTERSIGNED BY THE "GS" MARK.

- After rack assembly and few miles drive, ensure the bolts have been well tightened.
 - Periodically check the tightening of all bolts, with particular reference to the effect of varying road surfaces.
 - Caution: if the rack carries any load, vehicle stability may be affected, especially as regards roadholding in bends or in gusts and braking. Therefore, do not take bends at high speed and refrain from braking or accelerating sharply.
 - When not in use, the rack should be taken off the car to improve safety and cut down on fuel consumption.
 - It is not advisable to use a drive-through car wash with the rack still on top of the vehicle.
 - **IMPORTANT:** maximum load 50 kg to be distributed evenly between both bars.
- Please keep within the load limits as provided for by your car manufacturer (refer to the user's manual of your vehicle).

F MODE D'EMPLOI DES PORTE-BAGAGES UNIVERSELS CONFORMES AUX NORMES DIN 75302 ET CONTRESIGNE DE LA MARQUE "GS".

- Monter le porte-bagages: après quelques kilomètres, contrôler le serrage de toutes les vis.
- Vérifier périodiquement le serrage de toutes les vis en tenant compte de l'état des routes.
- Attention: la voiture équipée de porte-bagages peut subir des modifications dans la tenue de route, dans les virages, durant le freinage et en la présence de rafales de vent. Nous conseillons, par conséquent de conduire et d'aborder les virages à vitesse modérée et d'éviter de freiner et d'accélérer brusquement.
- Pour des raisons de sécurité et d'économie de carburant, il est préférable de démonter le porte-bagages en cas de non utilisation.
- **IMPORTANT:** capacité maximale de charge autorisée 50 kg, répartis uniformément sur les deux barres.
- Se conformer aux instructions du constructeur de la voiture en ce qui concerne la charge maximale autorisée du véhicule.

E INSTRUCCIONES DE USO DE LOS PORTATODOS UNIVERSALES CONFORME A LAS NORMAS DIN 75301 Y CONTRASEÑADOS CON LA MARCA "GS".

- Efectuado el montaje del portatodo, después de unos kilómetros, verificar que todos los tornillos sigan bien fijados.
 - Será necesario verificar, periódicamente y en función de tipo de carretera, las fijaciones de todos los tornillos.
 - Atención: la estabilidad del automóvil con el montaje del portatodo puede sufrir algunos cambios: en curvas, mientras el frenado y si hay ráfagas de viento. Pos eso, se recomienda conducir y girar a velocidad moderada y evitar los virajes bruscos, frenazos y acelerones.
 - Por razones de seguridad y ahorro de combustible, se sugiere desmontar el portatodo cuando no sea necesario su uso.
 - **IMPORTANTE:** peso máximo 50 kg repartidos entre las dos barras.
- Atención: verifiquen en el manual de instrucciones de su automóvil la capacidad máxima permitida.

D GEBRAUCHSANWEISUNG FÜR UNIVERSAL-DACHSKITRÄGER IM EINKLANG MIT DIN 75302 UND MIT GS-KENNZEICHEN.

- Fahren Sie nach Befestigung des Skiträgers einige Kilometer und überprüfen Sie dann nochmals alle Schrauben auf sichere Befestigung.
- Abhängig von der Ebenheit der Straßendecke sind sämtliche Schrauben regelmäßig nach zu kontrollieren.
- Achtung: Bei montiertem Dach-Skiträger kann sich das Fahrverhalten des Fahrzeugs ändern, insbesondere in Kurven, beim Bremsen und bei Windböen. Es empfiehlt sich daher, allgemein sowie speziell in Kurven mit mäßiger Geschwindigkeit zu fahren und abruptes Beschleunigen bzw. Bremsen zu vermeiden.
- Aus Sicherheitsgründen und zur Minderung des Kraftstoffverbrauchs sollten Sie den Dach-Skiträgers möglichst abmontieren wenn er nicht benötigt wird.
- **ACHTUNG:** (max 50 kg) In der Gebrauchsanweisung des Fabrikanten die Höchstbelastbarkeit Ihres Wagens nachschlagen.

NL GEBRUIKSNORMEN VAN DE BAGAGEDRAGERS IN OVEREENSTEMMING MET DIN 75302 NORMEN EN GECONTRASIGNEERD MET MERKTEKEN "GS".

- Controleer, eens de bagagedrager volledig is gemonteerd, na enkele kilometers of alle schroeven goed vastzitten.
 - Kijk achteraf en volgens de aard van de wegen die bereiden worden regelmatig na of alle schroeven wel degelijk vastzitten.
 - Let op: na het monteren van de bagagedrager kan de stabiliteit van de wagen verschillen, vooral in bochten, bij het remmen en bij krachtige windstoten. Wij raden dan ook aan voorzichtig te rijden, bochten met verminderde snelheid te nemen, niet te bruusk te nemen en niet te snel op te trekken.
 - Om veiligheidsredenen en om brandstof te besparen is het aangeraden de bagagedrager na gebruik weer van uw auto te halen.
 - **BELANGRUK:** maximum belasting 50 kg gelijkmatig verdeeld over de hele bagagedrager de maximum belasting van uw wagen.
- Aangegeven door de autoconstructeur in de handleiding van de wagen, niet overschrijden.

