

(D) MONTAGEANWEISUNGEN (GB) FITTING INSTRUCTIONS (F) INSTRUCTIONS DE MONTAGE
(E) INSTRUCCIONES PARA SU MONTAJE (IT) ISTRUZIONI DI MONTAGGIO (NL) MONTAGE INSTRUCTIES.

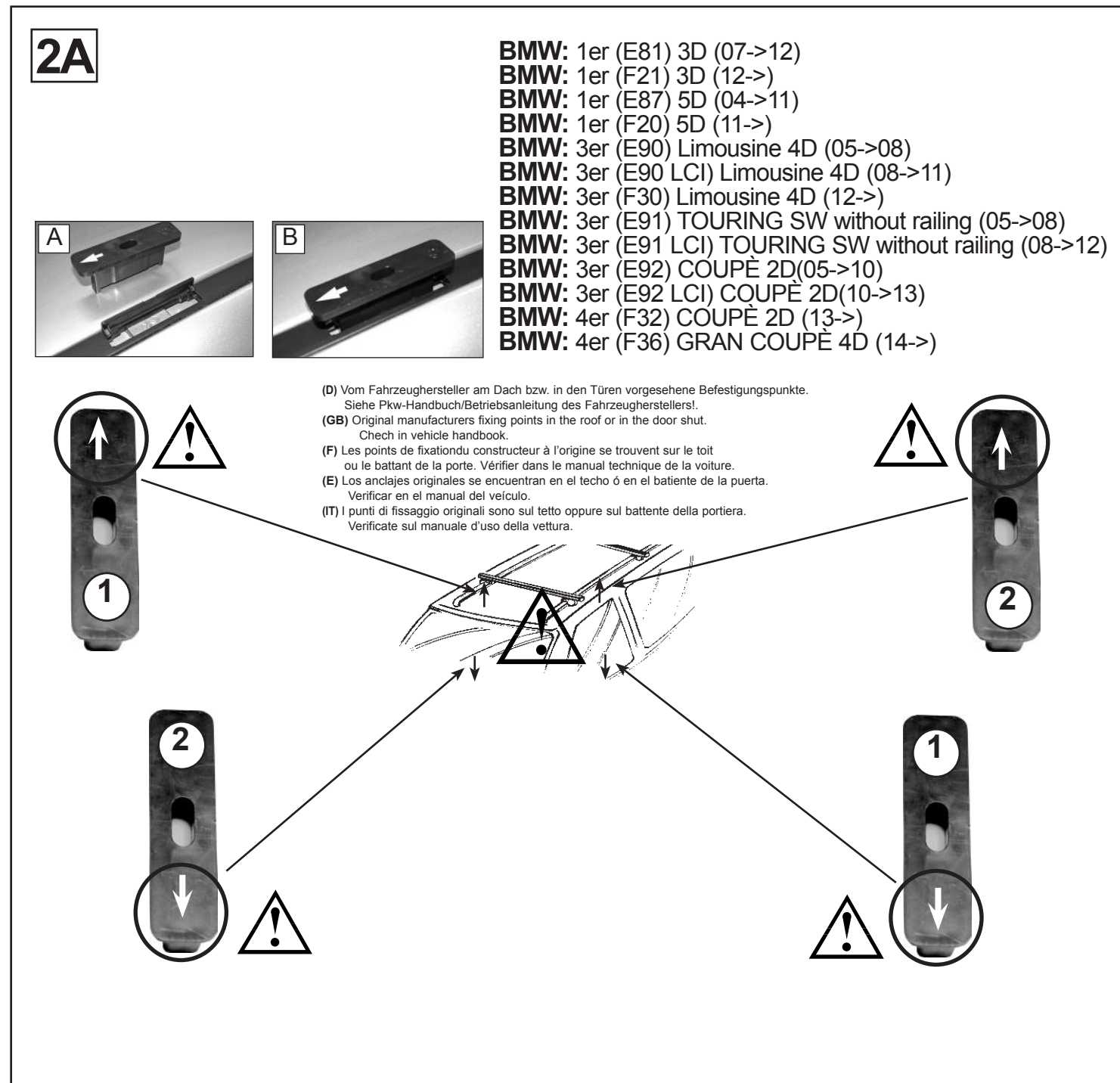

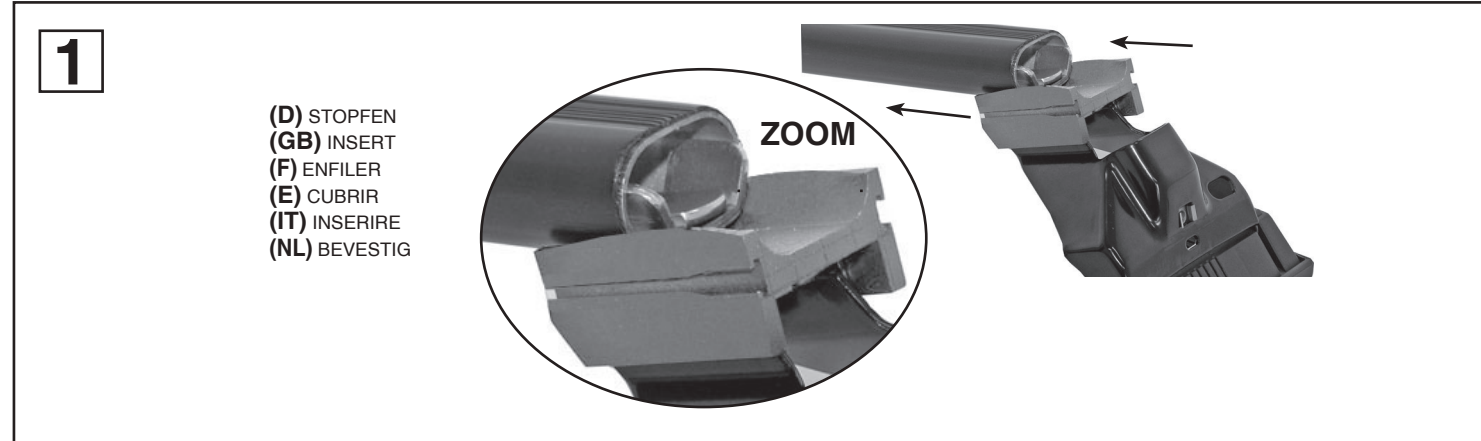

(D) FESTSCHRAUBEN
(GB) TO SCREW
(F) VISSER
(E) APRETAR
(IT) AVVITARE
(NL) VASTSCHROEVEN

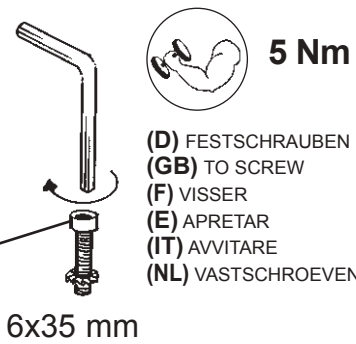

2B

6x35 mm

(D) AUTOS MIT VOM HERSTELLER VORGESEHENEN BEFESTIGUNGSPUNKTEN
(GB) CARS WITH PRE-EXISTING FIXING POINT FROM MANUFACTURER
(F) VOITURES AVEC POINTS DE RÉPÈRE PREVUS PAR LE CONSTRUCTEUR
(E) MODELOS CON PREDISPOSICION DEL FABRICANTE
(IT) MODELLI CON PREDISPOSIZIONE DELLA CASA AUTO
(NL) AUTO'S MET DOOR DE FABRIKANT VOORZIENE MONTAGEPUNTEN

- BMW:** 1er (E81) 3D (07->12)
- BMW:** 1er (F21) 3D (12->)
- BMW:** 1er (E87) 5D (04->11)
- BMW:** 1er (F20) 5D (11->)
- BMW:** 3er (E90) Limousine 4D (05->08)
- BMW:** 3er (E90 LCI) Limousine 4D (08->11)
- BMW:** 3er (F30) Limousine 4D (12->)
- BMW:** 3er (E91) TOURING SW without railing (05->08)
- BMW:** 3er (E91 LCI) TOURING SW without railing (08->12)
- BMW:** 3er (E92) COUPÉ 2D(05->10)
- BMW:** 3er (E92 LCI) COUPÉ 2D(10->13)
- BMW:** 4er (F32) COUPÉ 2D (13->)
- BMW:** 4er (F36) GRAN COUPÉ 4D (14->)

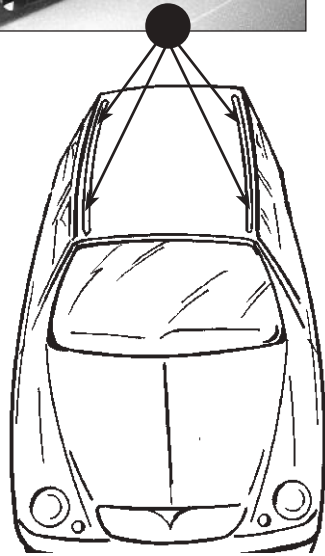

MERCEDES: A Class 5D (W169) (05->12) - B Class MPV (T245) (05->11)
MERCEDES: A Class COUPÉ 3D (W169) (05->12)

3B

(D) AUTOS MIT VOM HERSTELLER VORGESEHENEN BEFESTIGUNGSPUNKTEN
(GB) CARS WITH PRE-EXISTING FIXING POINT FROM MANUFACTURER
(F) VOITURES AVEC POINTS DE RÉPÈRE PREVUS PAR LE CONSTRUCTEUR
(E) MODELOS CON PREDISPOSICION DEL FABRICANTE
(IT) MODELLI CON PREDISPOSIZIONE DELLA CASA AUTO
(NL) AUTO'S MET DOOR DE FABRIKANT VOORZIENE MONTAGEPUNTEN

(D) FESTSCHRAUBEN
(GB) TO SCREW
(F) VISSER
(E) APRETAR
(IT) AVVITARE
(NL) VASTSCHROEVEN

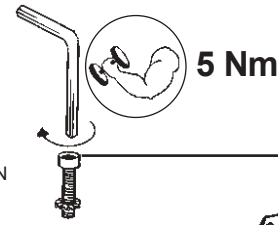

6x35 mm

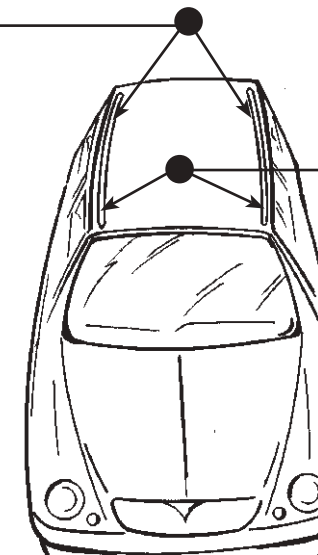

6x40 mm

(D) FESTSCHRAUBEN
(GB) TO SCREW
(F) VISSER
(E) APRETAR
(IT) AVVITARE
(NL) VASTSCHROEVEN

(D) FESTSCHRAUBEN
(GB) TO SCREW
(F) VISSER
(E) APRETAR
(IT) AVVITARE
(NL) VASTSCHROEVEN

5 Nm

(D) FESTSCHRAUBEN
(GB) TO SCREW
(F) VISSER
(E) APRETAR
(IT) AVVITARE
(NL) VASTSCHROEVEN



MERCEDES: A Class 5D (W169) (05->12) - B Class MPV (T245) (05->11)
MERCEDES: A Class COUPÉ 3D (W169) (05->12)

3A



(D) Vom Fahrzeughersteller am Dach bzw. in den Türen vorgesehene Befestigungspunkte.
 Siehe Pkw-Handbuch/Betriebsanleitung des Fahrzeugherstellers!
(GB) Original manufacturers fixing points in the roof or in the door shut.
 Check in vehicle handbook.
(F) Les points de fixation du constructeur à l'origine se trouvent sur le toit
 ou le battant de la porte. Vérifier dans le manuel technique de la voiture.
(E) Los anclajes originales se encuentran en el techo ó en el batiente de la puerta.
 Verificar en el manual del vehículo.
(IT) I punti di fissaggio originali sono sul tetto oppure sul battente della portiera.
 Verificate sul manuale d'uso della vettura.

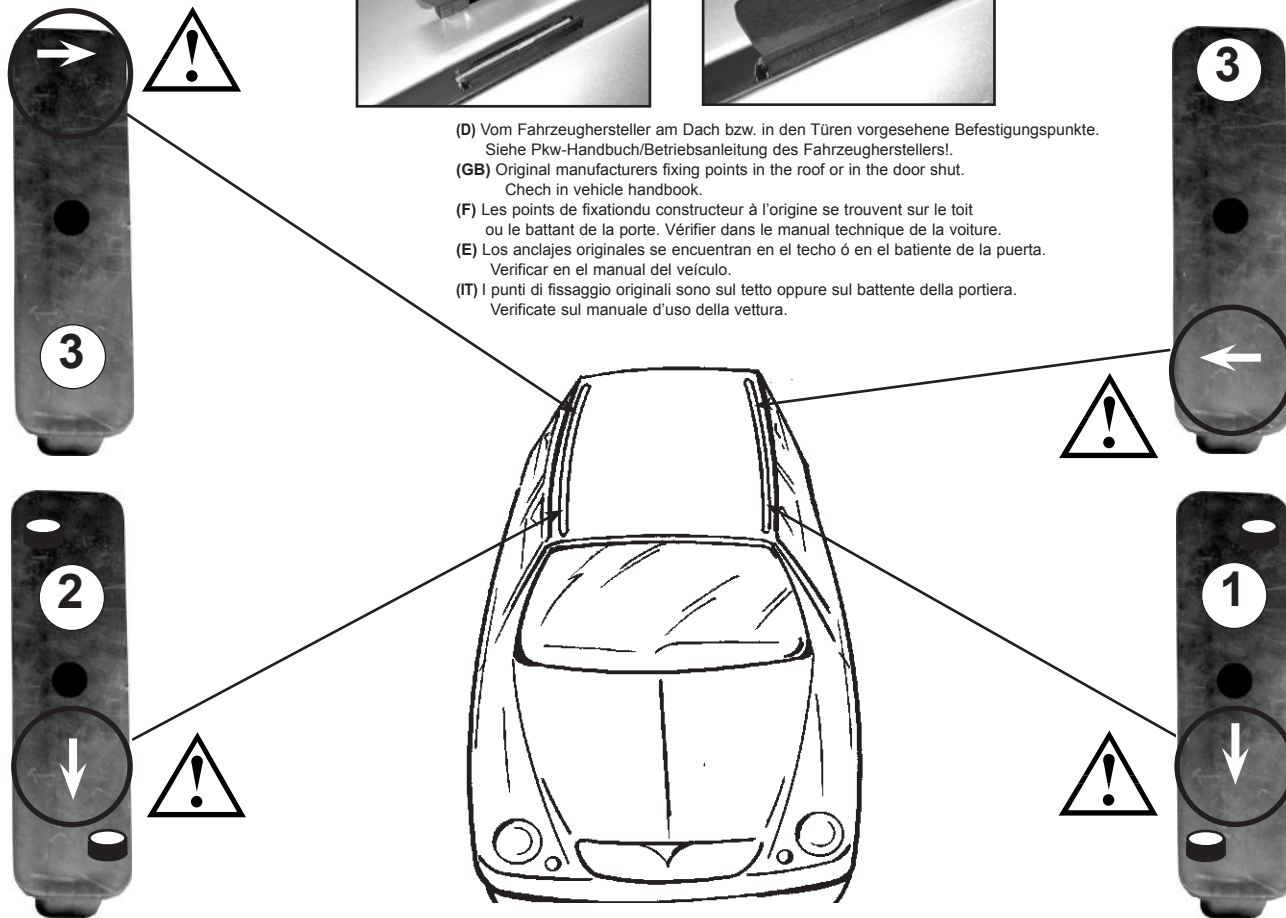

4

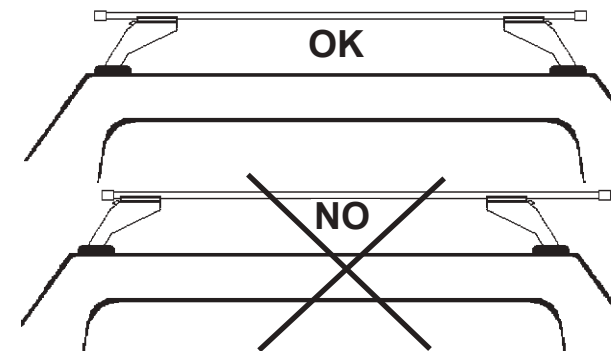



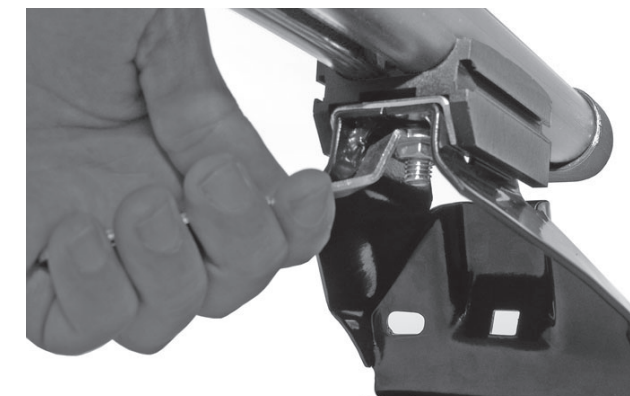

(D) LASTENTRÄGER AUF DEM DACH ZENTRIEREN
(GB) CENTRE THE UNIVERSAL BAR CARRIER ON THE ROOF
(F) CENTRER LE PORTE-TOUT SUR LE TOIT
(E) CENTRAR EL PORTAEQUIPAJES SOBRE EL TECHO
(IT) CENTRARE IL P. TUTTO SUL TETTO
(NL) PLAATS DE UNIVERSELE DRAGER IN HET MIDDEN VAN HET DAK

5



(D) FESTSCHRAUBEN
(GB) TO SCREW (DOWN)
(F) VISSER (À FONDS)
(E) APRETAR (A FONDO)
(IT) AVVITARE (A FONDO)
(NL) VASTSCHROEVEN

10 Nm

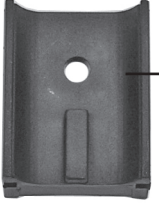
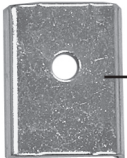
-  x4 Cod. VTBS08P30
-  x4 Cod. 32052/Z
-  x4 Cod. ROZB08016
-  x4 Cod. DDFZ08001
-  x4 Cod. 60328
-  x4 Cod. 32053/Z

MERCEDES

x1 Cod. 60248

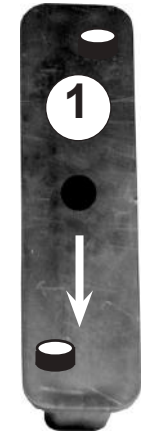

1

x1 Cod. 60249

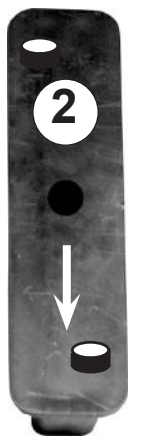

2

x2 Cod. 60250

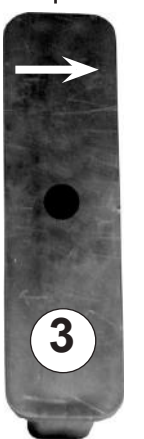

3

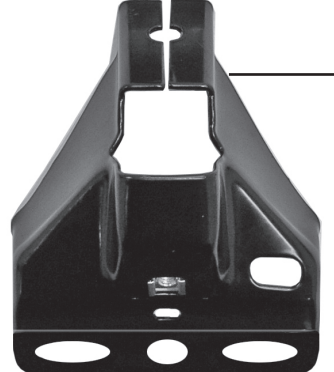

x4 Cod. 31060/V

BMW

x2 Cod. 63115



1

x2 Cod. 63116



2

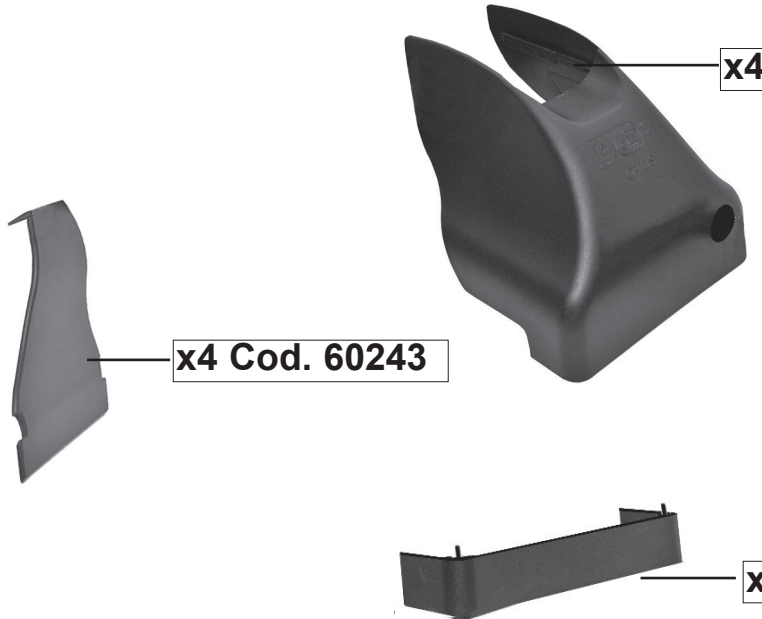

- x4 Cod. 60285/TW
- x4 Cod. 60243
- x4 Cod. 60260

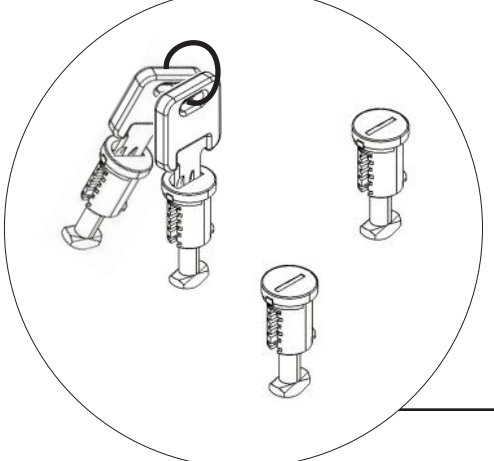

x1 Cod. 57732

6x40 mm



x2 Cod. VTBB06040

Ø 6x24 mm



x4 Cod. ROZB06024

6x35 mm



x6 Cod. VTBB06035

Ø 6x18 mm



x4 Cod. ROZB06018

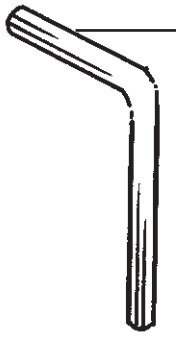

x1 Cod. 57543

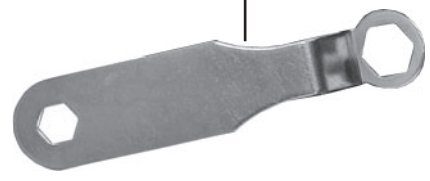

x1 Cod. 32032/Z

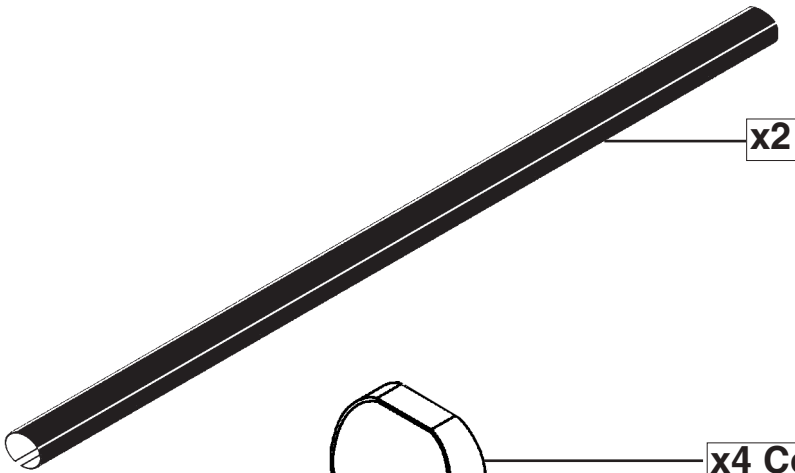

x2 Cod. 37919/C

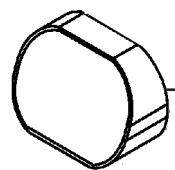

x4 Cod. 60227/TW

TWINNY
LOAD

FINAL
A 14 / S 14
A 25 / S 25
A 27 / S 27
A 37 / S 37
A 47 / S 47

(D) MONTAGEANWEISUNGEN (GB) FITTING INSTRUCTIONS
(F) INSTRUCTIONS DE MONTAGE (E) INSTRUCCIONES PARA SU MONTAJE
(IT) ISTRUZIONI DI MONTAGGIO (NL) MONTAGE INSTRUCTIES

COVERS

1

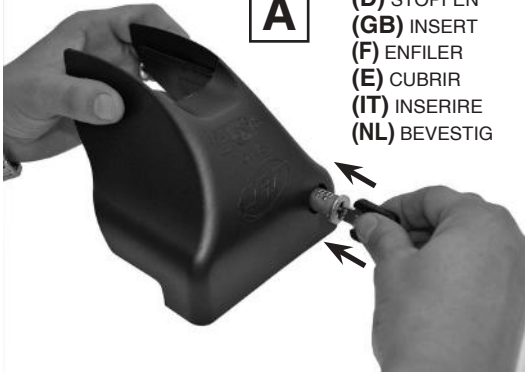

A

(D) STOPFEN
(GB) INSERT
(F) ENFILER
(E) CUBRIR
(IT) INSERIRE
(NL) BEVESTIG

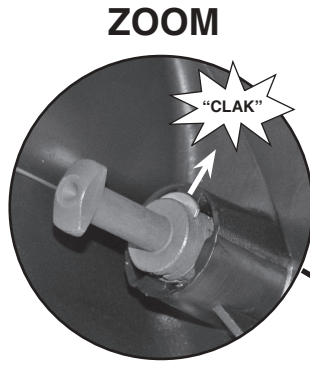

ZOOM

B

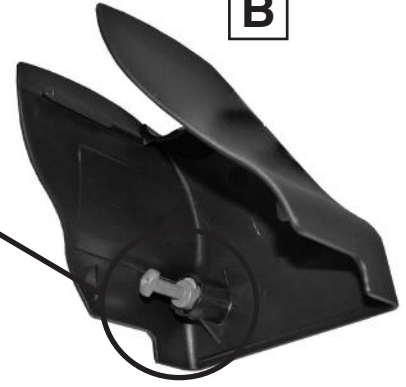

C

(D) STOPFEN
(GB) INSERT
(F) ENFILER
(E) CUBRIR
(IT) INSERIRE
(NL) BEVESTIG

2

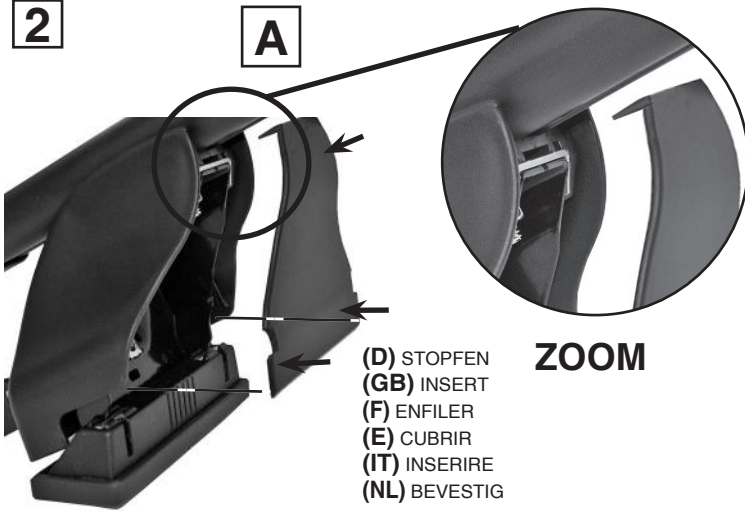

A

ZOOM

(D) STOPFEN
(GB) INSERT
(F) ENFILER
(E) CUBRIR
(IT) INSERIRE
(NL) BEVESTIG

B



(D) STOPFEN
(GB) INSERT
(F) ENFILER
(E) CUBRIR
(IT) INSERIRE
(NL) BEVESTIG

3

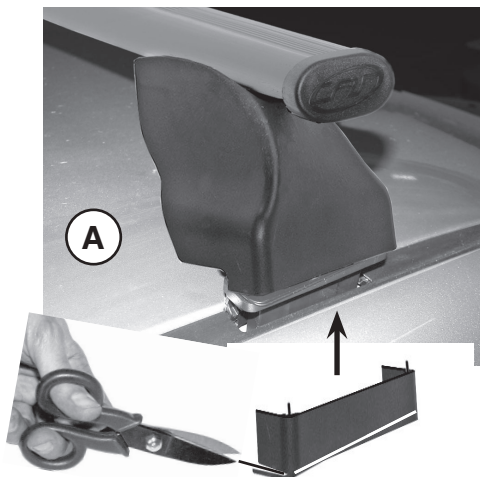

A

(D) STOPFEN
(GB) INSERT
(F) ENFILER
(E) CUBRIR
(IT) INSERIRE
(NL) BEVESTIG

B

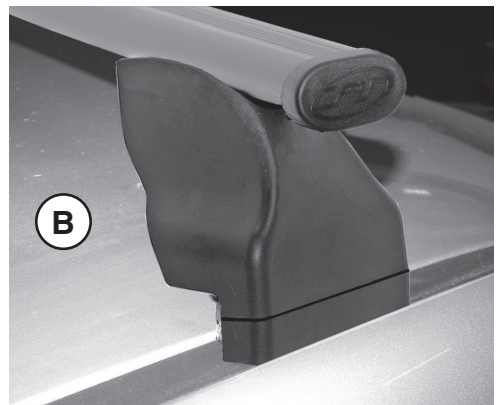

I NORME D'USO DESTINATE A PORTATUTTO UNIVERSALI CONFORMI ALLE NORME DIN 75302 E CONTRASSEGNA TI CON IL MARCHIO "GS".

- Effettuato il montaggio del portatutto, dopo alcuni chilometri ricontrrollare il fissaggio di tutte le viti.
 - È necessario periodicamente, anche in funzione del fondo stradale, controllare i fissaggi di tutte le viti.
 - Attenzione: la stabilità della vettura con portatutto montato può subire alterazioni nel comportamento su strada, nelle curve, nelle frenate ed in presenza di raffiche di vento. Si raccomanda quindi di guidare ed affrontare le curve a velocità moderata e di evitare brusche accelerate o frenate.
 - Per motivi di sicurezza e di risparmio carburante è preferibile smontare il portatutto in caso di inutilizzo.
 - **ATTENZIONE:** portata massima 50 kg distribuiti uniformemente sulle due barre.
- Attenzione: controllare sul libretto istruzioni della casa costruttrice la portata massima consentita dalla vostra vettura.

GB USING THE MULTI-PURPOSE RACK A3 PROVIDED FOR BY THE DIN 75302 STANDARD AND COUNTERSIGNED BY THE "GS" MARK.

- After rack assembly and few miles drive, ensure the bolts have been well tightened.
 - Periodically check the tightening of all bolts, with particular reference to the effect of varying road surfaces.
 - Caution: if the rack carries any load, vehicle stability may be affected, especially as regards roadholding in bends or in gusts and braking. Therefore, do not take bends at high speed and refrain from braking or accelerating sharply.
 - When not in use, the rack should be taken off the car to improve safety and cut down on fuel consumption.
 - It is not advisable to use a drive-through car wash with the rack still on top of the vehicle.
 - **IMPORTANT:** maximum load 50 kg to be distributed evenly between both bars.
- Please keep within the load limits as provided for by your car manufacturer (refer to the user's manual of your vehicle).

F MODE D'EMPLOI DES PORTE-BAGAGES UNIVERSELS CONFORMES AUX NORMES DIN 75302 ET CONTRESIGNE DE LA MARQUE "GS".

- Monter le porte-bagages: après quelques kilomètres, contrôler le serrage de toutes les vis.
- Vérifier périodiquement le serrage de toutes les vis en tenant compte de l'état des routes.
- Attention: la voiture équipée de porte-bagages peut subir des modifications dans la tenue de route, dans les virages, durant le freinage et en la présence de rafales de vent. Nous conseillons, par conséquent de conduire et d'aborder les virages à vitesse modérée et d'éviter de freiner et d'accélérer brusquement.
- Pour des raisons de sécurité et d'économie de carburant, il est préférable de démonter le porte-bagages en cas de non utilisation.
- **IMPORTANT:** capacité maximale de charge autorisée 50 kg, répartis uniformément sur les deux barres.
- Se conformer aux instructions du constructeur de la voiture en ce qui concerne la charge maximale autorisée du véhicule.

E INSTRUCCIONES DE USO DE LOS PORTATODOS UNIVERSALES CONFORME A LAS NORMAS DIN 75301 Y CONTRASEÑADOS CON LA MARCA "GS".

- Efectuado el montaje del portatodo, después de unos kilómetros, verificar que todos los tornillos sigan bien fijados.
 - Será necesario verificar, periódicamente y en función de tipo de carretera, las fijaciones de todos los tornillos.
 - Atención: la estabilidad del automóvil con el montaje del portatodo puede sufrir algunos cambios: en curvas, mientras el frenado y si hay ráfagas de viento. Por eso, se recomienda conducir y girar a velocidad moderada y evitar los virajes bruscos, frenazos y acelerones.
 - Por razones de seguridad y ahorro de combustible, se sugiere desmontar el portatodo cuando no sea necesario su uso.
 - **IMPORTANTE:** peso máximo 50 kg repartidos entre las dos barras.
- Atención: verifiquen en el manual de instrucciones de su automóvil la capacidad máxima permitida.

D GEBRAUCHSANWEISUNG FÜR UNIVERSAL-DACHSKITRÄGER IM EINKLANG MIT DIN 75302 UND MIT GS-KENNZEICHEN.

- Fahren Sie nach Befestigung des Skiträgers einige Kilometer und überprüfen Sie dann nochmals alle Schrauben auf sichere Befestigung.
- Abhängig von der Ebenheit der Straßendecke sind sämtliche Schrauben regelmäßig nach zu kontrollieren.
- Achtung: Bei montiertem Dach-Skiträger kann sich das Fahrverhalten des Fahrzeugs ändern, insbesondere in Kurven, beim Bremsen und bei Windböen. Es empfiehlt sich daher, allgemein sowie speziell in Kurven mit mäßiger Geschwindigkeit zu fahren und abruptes Beschleunigen bzw. Bremsen zu vermeiden.
- Aus Sicherheitsgründen und zur Minderung des Kraftstoffverbrauchs sollten Sie den Dach-Skiträger möglichst abmontieren wenn er nicht benötigt wird.
- **ACHTUNG:** (max 50 kg) In der Gebrauchsanweisung des Fabrikanten die Höchstbelastbarkeit Ihres Wagens nachschlagen.

NL GEBRUIKSNORMEN VAN DE BAGAGEDRAGERS IN OVEREENSTEMMING MET DIN 75302 NORMEN EN GECONTRASIGNEERD MET MERKTEKEN "GS".

- Controleer, eens de bagagedrager volledig is gemonteerd, na enkele kilometers of alle schroeven goed vastzitten.
 - Kijk achteraf en volgns de aard van de wegen die bereiden worden regelmatig na of alle schroeven wel degelijk vastzitten.
 - Let op: na het monteren van de bagagedrager kan de stabiliteit van de wagen verschillen, vooral in bochten, bij het remmen en bij krachtige windstoten. Wij raden dan ook aan voorzichtig te rijden, bochten met verminderde snelheid te nemen, niet te bruusk te nemen en niet te snel op te trekken.
 - Om veiligheidsredenen en om brandstof te besparen is het aangeraden de bagagedrager na gebruik weer van uw auto te halen.
 - **BELANGRUK:** maximum belasting 50 kg gelijkmatig verdeeld over de hele bagagedrager de maximum belasting van uw wagen.
- Aangegeven door de autoconstructeur in de handleiding van de wagen, niet overschrijden.

